



TRUE FOOD SERVICE EQUIPMENT, INC.

2001 East Terra Lane • P.O. Box 970 • O'Fallon, Missouri 63366
 (636)240-2400 • Fax (636)272-2408 • (800)325-6152 • Intl Fax# (001)636-272-7546
 Parts Dept. (800)424-TRUE • Parts Dept. Fax# (636)272-9471 • www.truemfg.com

Project Name: _____

A/A #

Location: _____

Item #: _____ Qty: _____

SIS #

Model #: _____

Model:
GDIM-49

Ice Merchandiser:
Glass Door



GDIM-49

- ▶ The world's #1 manufacturer of glass door merchandisers.
- ▶ Designed using the highest quality materials and components to provide the user with an attractive, point of purchase ice merchandiser.
- ▶ Oversized, factory balanced, refrigeration system holds 20°F to 25°F (-6.6°C to -3.8°C).
- ▶ Exterior - non-peel or chip white laminated vinyl; durable and permanent.
- ▶ Interior - attractive, NSF approved, white aluminum interior liner with 300 series stainless steel floor. Interior floor rack and backguard standard.
- ▶ Self closing doors. Positive seal, torsion type closure system.
- ▶ Heated, triple pane thermal insulated glass door assemblies with extruded aluminum frames.
- ▶ Patented integrated door light (IDL) system for brighter, shadow free illumination.
- ▶ Entire cabinet structure is foamed-in-place using high density, CFC free, polyurethane insulation.
- ▶ Holds (100) 8 lbs. (4 kg) bags of ice.

ROUGH-IN DATA

Specifications subject to change without notice.
 Chart dimensions rounded up to the nearest 1/8" (millimeters rounded up to next whole number).

| Model | Doors | Capacity (Cu. Ft.) (liters) | Floor Racks | Cabinet Dimensions (inches) (mm) | | | HP | Voltage | Amps | NEMA Config. | Cord Length (total ft.) (total m) | Crated Weight (lbs.) (kg) |
|---------|-------|-----------------------------|-------------|--|---------------------------------------|--|------------|--------------------------|-------------|--------------|-----------------------------------|---------------------------|
| | | | | L | D† | H | | | | | | |
| GDIM-49 | 2 | 49 1388 | 2 | 54 ¹ / ₈ 1375 | 29 ⁷ / ₈ 759 | 78 ⁵ / ₈ 1998 | 1/2 1/2 | 115/60/1 230-240/50/1 | 10.2 6.9 | 5-15P ▲ | 9 2.74 | 505 230 |

† Depth does not include 11/8" (29 mm) for door handles.

▲ Plug type varies by country.

3/08 Printed in U.S.A.

APPROVALS:

AVAILABLE AT:

Model:
GDIM-49

Ice Merchandiser:
Glass Door



STANDARD FEATURES

DESIGN

- True's commitment to using the highest quality materials and oversized refrigeration systems provides the user with colder product temperatures, and lower utility costs in an attractive ice merchandiser.

REFRIGERATION SYSTEM

- Factory engineered, self-contained, capillary tube system using environmentally friendly (CFC free) 134A refrigerant.
- Extra large evaporator coil balanced with higher horsepower compressor and large condenser; maintains 20°F to 25°F (-6.6°C to -3.8°C) cabinet temperature.
- Sealed, cast iron, self-lubricating evaporator fan motor(s) and larger fan blades give True merchandisers a more efficient low velocity, high volume airflow design. This unique design ensures colder standard temperatures and faster recovery in high use situations.
- Bottom mounted condensing unit positioned for easy maintenance; "No stoop" design maximizes visibility by raising merchandised product to higher level.
- Automatic defrost system time-initiated, temperature-terminated. Saves energy consumption and provides shortest possible defrost cycle.

CABINET CONSTRUCTION

- Exterior - non-peel or chip white laminated vinyl; durable and permanent.
- Interior - attractive, NSF approved, white aluminum interior liner with 300 series stainless steel floor.

- Insulation - entire cabinet structure is foamed-in-place using high density, CFC free, polyurethane insulation.
- Welded, heavy duty galvanized frame rail dipped in rust inhibiting enamel paint for corrosion protection inside and out.
- Frame rail fitted with leg levelers.
- Illuminated exterior sign panel.

DOORS

- Heated, triple pane thermal insulated glass door assemblies with extruded aluminum frames. Minimizes condensation build up on glass for more effective merchandising.
- Each door fitted with 12" (305 mm) long extruded handle.
- Self closing doors. Positive seal, torsion type closure system.
- Magnetic door gaskets of one piece construction, removable without tools for ease of cleaning.

STORAGE CAPACITY

- Interior floor racks and backguards prevent bags of ice from blocking optimal airflow.
- 12" (305 mm) interior basin to protect from melt-down of product.
- Holds (100) 8 lbs. (4 kg) bags of ice.

LIGHTING

- Fluorescent interior lighting. Each glass door utilize full-length, patented, integrated door light (IDL) system. Safety shielded.
- Cabinet lighting utilizes electronic ballast and T-8 bulbs for brighter illumination, longer bulb life and increased energy efficiency.

MODEL FEATURES

- Evaporator is epoxy coated to eliminate the potential of corrosion.
- Listed under NSF-7 for the storage and/or display of packaged or bottled product.

ELECTRICAL

- Unit completely pre-wired at factory and ready for final connection to a 115/60/1 phase - 15 amp dedicated outlet. Cord and plug set included.



115/60/1
NEMA-5-15R

OPTIONAL FEATURES/ACCESSORIES

Upcharge and lead times may apply.

- 230-240V / 50 Hz.
- Black exterior.
- Rosewood exterior.
- Stainless steel exterior.
- Black aluminum interior liner.
- 6" (153 mm) standard legs.
- 6" (153 mm) seismic/flanged legs.
- 2 1/2" (64 mm) diameter castors.
- 4" (102 mm) diameter castors.
- Padlocks.
- Remote cabinets (condensing unit supplied by others; system comes standard with 404A expansion valve and requires R404A refrigerant). Consult factory technical service department for BTU information.

PLAN VIEW

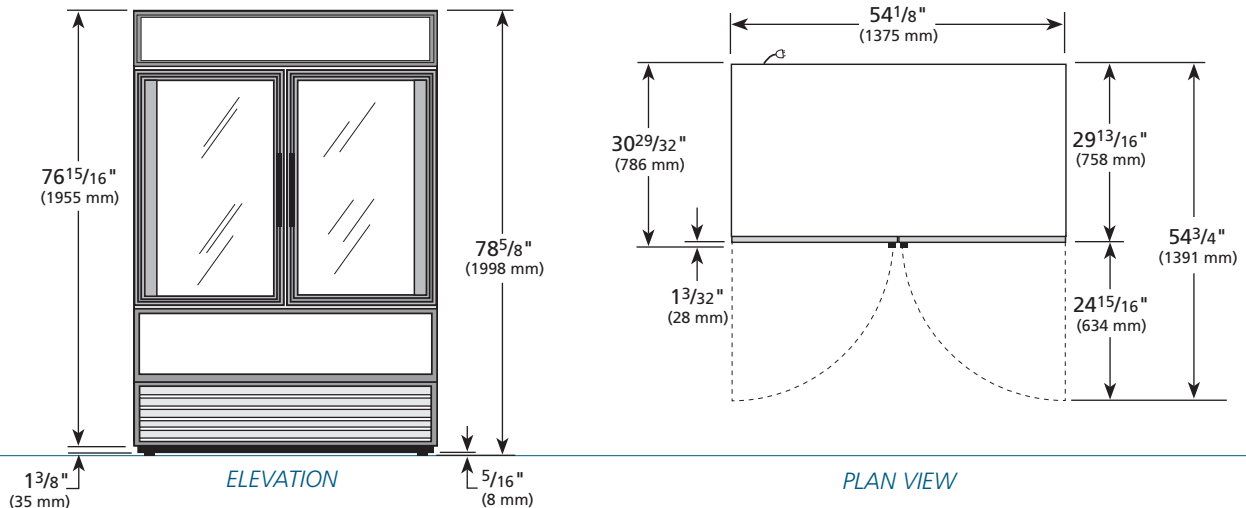

WARRANTY

One year warranty on all parts and labor and an additional 4 year warranty on compressor. (U.S.A. only)

METRIC DIMENSIONS ROUNDED UP TO THE NEAREST WHOLE MILLIMETER
SPECIFICATIONS SUBJECT TO CHANGE WITHOUT NOTICE



| Model | Elevation | Right | Plan | 3D |
|---------|-----------|---------|---------|---------|
| GDIM-49 | TFRY05E | TFRY05S | TFRY05P | TFRY053 |

TRUE FOOD SERVICE EQUIPMENT

2001 East Terra Lane • P.O. Box 970 • O'Fallon, Missouri 63366 • (636)240-2400 • Fax (636)272-2408 • (800)325-6152 • Intl. Fax# (001)636-272-7546 • www.truemfg.com